

creative conners, inc.

# Stagehand AC Reference Manual

Version 2.1

## Contents

Stagehand™ AC Reference Manual .....	3
1– Getting Started .....	3
1.1 What’s in the box?.....	3
1.2 Stagehand AC Overview .....	3
1.3 Installing Stagehand .....	7
1.3.1 Mounting Stagehand.....	7
<i>Figure 1.3</i> .....	7
1.3.2 Hooking up power.....	7
1.3.3 Hooking up a motorized effect .....	8
1.3.4 Testing a motor .....	11
1.4 Configuring a Stagehand Network.....	12
2– Using a Stagehand .....	13
2.1 Manual Operation .....	13
2.2 Computer Control with SpikeMark .....	14
2.3 Adjust the Stagehand AC Control Output .....	14
3– Troubleshooting.....	18
Stagehand lost power and now the position information is incorrect.....	18
Motor won’t run in cue.....	18
Motor won’t run with jog controls. ....	18
Motor runs fine with jog controls, but won’t run from SpikeMark.....	18
When running a cue, the motor speeds fast in the wrong direction and then turns off. ....	18
When running a cue, the motor speeds fast in the right direction and then turns off. ....	19
Technical Support .....	19
Phone Support .....	19
Web Support.....	19
Email .....	19
4– Specifications.....	19
4.1 Physical Specifications.....	19
4.2 Electrical Specifications.....	20
4.3 Adjusting Mitsubishi Drive Parameters .....	20
4.4 Default Mitsubishi Drive Parameters .....	21
4.5 Drive Auto-Tuning .....	21

# Stagehand™ AC Reference Manual

## 1 – Getting Started

Congratulations on your purchase of the Stagehand AC scenic motion controller from Creative Conners, Inc. Stagehand AC brings the excitement of automation to theatres of all sizes. Stagehand AC is a unique combination of motion controller and motor drive that eliminates the clutter and complexity of other automation systems.

This manual will direct you through:

1. Unpacking
2. Installing & testing
3. Operation procedures

If you need help along the way contact us either on our website ([www.creativeconners.com](http://www.creativeconners.com)), via email ([support@creativeconners.com](mailto:support@creativeconners.com)), or by phone (401.862.2980)

### 1.1 What's in the box?

Inside the box you should find:

1. Reference manual (this document)
2. Stagehand AC motion controller
3. 7-pin encoder connector
4. Mitsubishi A700 instructions on CD

If any of these items are missing, please contact us immediately for a replacement.

If you purchased any power cables, encoders, limit switches, or other accessories, those items are packaged separately.

### 1.2 Stagehand AC Overview

The Stagehand AC performs two major functions: motion control and power amplification. This means that Stagehand can:

1. Track the position of a motor that is equipped with a quadrature encoder.
2. Control the speed, acceleration, and position of a motor that is equipped with a quadrature encoder.
3. Supply the power necessary to move the motor.

Typically these functions have been divided between two or more pieces of equipment, but Stagehand packs all of this functionality into one convenient box.

After unpacking your Stagehand AC, take a moment to familiarize yourself with its various connections and features.



*Figure 1.1*

Figure 1.1 shows the connections located on the face of the Stagehand AC. From left to right, top to bottom, these connections are:

1. **Forward jog button** – When pressed the Stagehand will switch to manual operation, and begin to jog in the forward direction.
2. **Reverse jog button** – When pressed the Stagehand will switch to manual operation, and begin to jog in the reverse direction.
3. **LCD Display** – The display shows information about the Stagehand’s status. When idle, it shows the current IP address and the status of the network connection between the **Stagehand** and a PC running **SpikeMark**. If a limit switch or E-Stop has been activated,
  - a. the condition will be displayed. In jog mode, it will display the jog direction and speed. In address mode, it will let you alter the current IP address.
4. **Knob** – The **knob** performs different functions depending on the function being performed:
  - a. If either **jog button** is pressed, the **knob** will function as a speed dial.

- b. To set the IP address, press the **knob** (it's also a button) and then turn the **knob** to adjust the address
5. **Ethernet** – The Ethernet receptacle accepts a standard RJ45 network cable. Stagehand AC uses Ethernet as the control protocol to communicate with a PC running SpikeMark™ software.
6. **Encoder Battery Backup** - To protect against encoder position loss during power interruption, you can insert two (2) 9V batteries into the encoder battery backup. The batteries will continue to supply power to the encoder and motion controller if mains power is lost for up to 30 minutes.
7. **Encoder** – The encoder receptacle is a Amphenol T3107 000 connector. This receptacle provides power (24VDC) to, and receives position information from, a quadrature encoder. **Note: The encoder allows Stagehand to track a motor's position.**
8. **FWD Limit** – The forward limit receptacle is a NEMA midget connector (ML1). This receptacle is used to connect a limit switch that will detect the end of forward travel for your machine. The limit should be wired as normally closed switch (N.C.).
9. **REV Limit** – The reverse limit receptacle is a NEMA midget connector (ML1). This receptacle is used to connect a limit switch that will detect the end of reverse travel for your machine. The limit should be wired as normally closed switch (N.C.).
10. **E-Stop** – The E-Stop (a.k.a. emergency stop) receptacle is a 5-pin XLR connector. This receptacle receives a dedicated emergency signal (24VDC) from a Showstopper base station. If this signal is present, the Stagehand is free to move, when the signal is interrupted it will immediately remove power from the motor.
11. **Keypad** - The keypad allows you to adjust the configuration parameters of the internal variable frequency drive. The keypad also displays useful motor status information such as output speed, output current, and output voltage. New in this version of the Stagehand product, we are now using the Mitsubishi A700 drive inside the Stagehand AC.
12. **Main Power Indicator** - A green power indicator is illuminated on the face of the Stagehand when mains power is present.

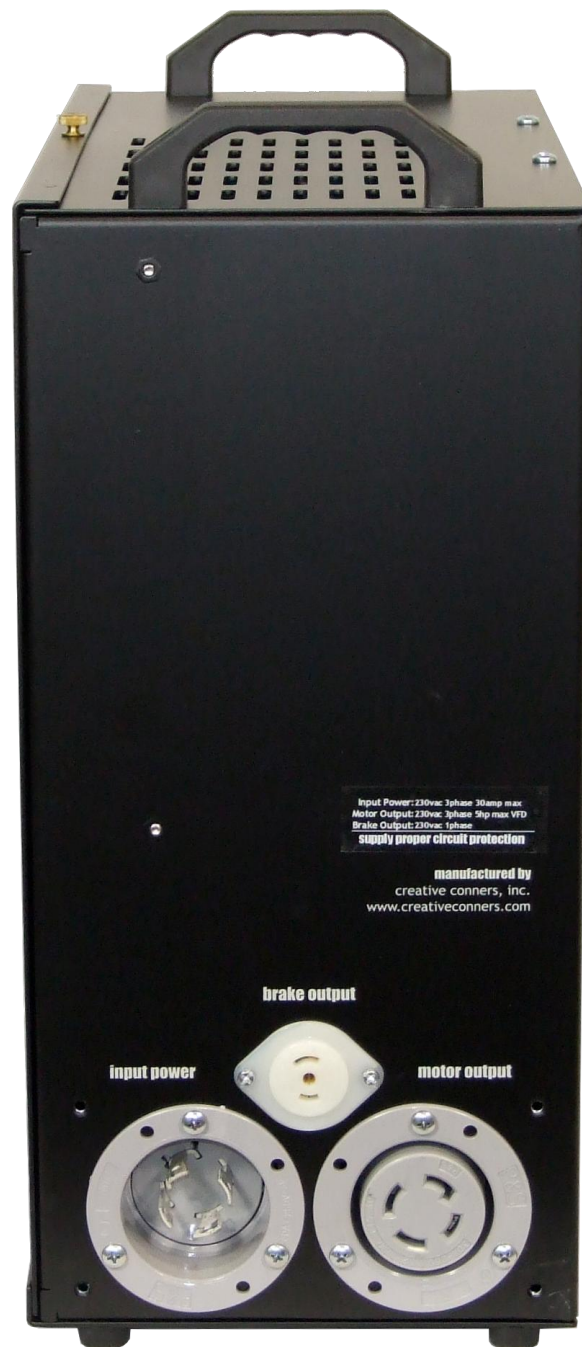

Figure 1.2

Figure 1.2 shows the power connections located on the back of the Stagehand AC. From left to right, top to bottom these connections are:

1. **Brake Power** – The brake power receptacle is a NEMA midget connector (ML3). This receptacle supplies AC power for your spring-set brake at 208/230VAC.
2. **Input Power** – The power input connector is a NEMA L15-30 (3-phase, 230V, 30amp).
3. **Output Power** – The output power socket supplies power to your motor. This connector is a NEMA L15-30 (3-phase, 230V, 30amp).

## 1.3 Installing Stagehand

### 1.3.1 Mounting Stagehand

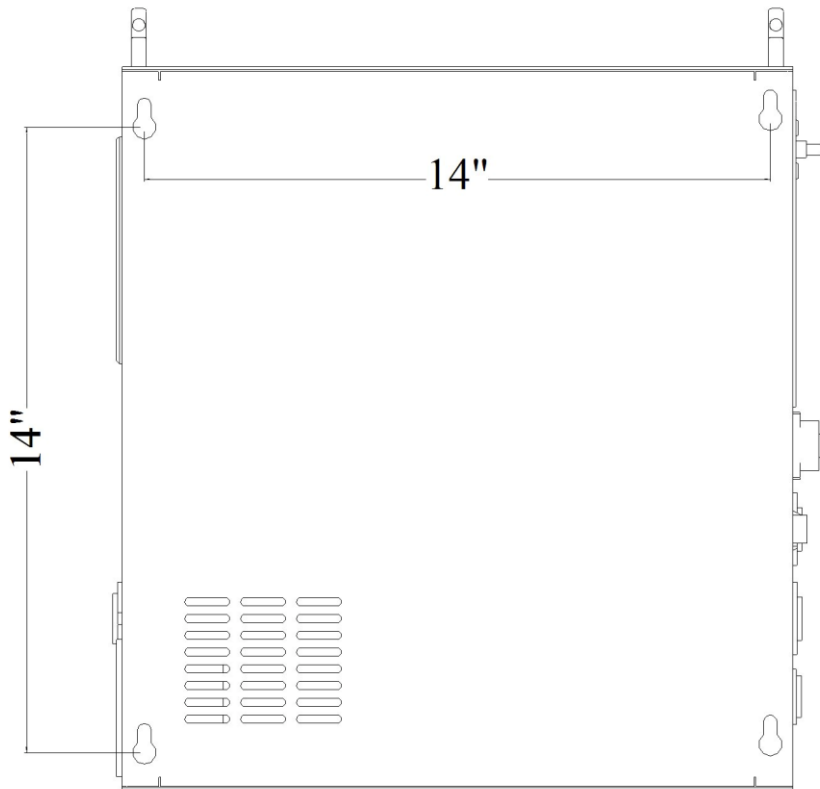

*Figure 1.3*

The Stagehand AC was designed to either sit freestanding on its rubber feet, or mount to a vertical surface using its four keyhole mountings on the side. Figure 1.3 shows the location of the keyholes that can be used to mount the panel to a wall or portable stand. The Stagehand should be mounted in a location that is moderate in temperature (40°F-90°F) as well as free from excessive dust and moisture. The internal drive in the Stagehand AC generates heat, and needs to remain well ventilated to prolong its working life. Do not block the venting slots on the top, and make sure at least one of the bottom venting slots remains clear.

Typically, it is best to mount the Stagehand AC within 6' of the motor it controls. This reduces cable clutter and minimizes the risk of electrical interference (both RFI & EMI). Longer distances are possible with motor, encoder, and limit cable extensions.

### 1.3.2 Hooking up power

Stagehand needs power to store a motor's position information & to drive a motor. **Care should be taken to power the Stagehand from a source that is not likely to be interrupted. If power is lost to a Stagehand, the motor's position information will be reset to zero (0), regardless of the motor's actual position.**

**Stagehand AC** should be connected with a NEMA L15-30 cord-style receptacle that is wired as shown:

*Figure 1.4*

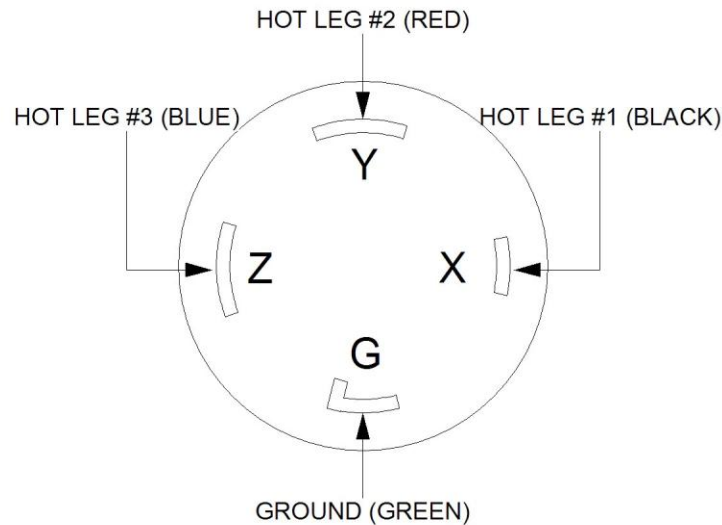

To reduce the risk of fire and equipment damage, Stagehand AC's should be installed with proper branch circuit protection. Install a properly sized circuit breaker on the dedicated circuit supplying power to the Stagehand. Breaker sizing should be matched with the motor in use.

Once you have applied power, the LCD display should light up and display the following (note: IP address may be different).

Figure 1.5



The “E-Stop!!” message is displayed because you have not yet hooked up the Stagehand with Showstopper. If the Stagehand does not detect a signal from Showstopper, it will assume an Emergency Stop condition.

The number on the bottom line of the display is the Stagehand's IP address. We'll look at changing the IP address in section 1.4.

### 1.3.3 Hooking up a motorized effect

If you are using a **Pushstick** or other motorized effect from Creative Conners, making connections to the **Stagehand AC** is easy. With the **Showstopper E-Stop** engaged:

1. Connect the encoder to the **encoder socket**.
2. Connect the brake to the **brake socket**.
3. Connect the motor to the **motor socket**.
4. Connect either the forward limit or a limit jumper to the **forward limit socket**. *Note: A limit jumper is a MLI plug that has a wire connected between the two pins on the plug.*

*This will simulate a normally closed limit switch, thus allowing travel in the forward direction.*

5. Connect either the reverse limit or a limit jumper to the **reverse limit socket**.
6. Using a network cable (RJ45 Cat5), connect the **Ethernet socket** to an Ethernet hub.
7. Using a **Showstopper cable** (5-pin XLR) connect the **Showstopper** to the **E-Stop** inlet on the **Stagehand AC**.

If you are using your own motorized effect, you will need to install connectors on your devices prior to connecting to the **Stagehand AC**. The following diagrams show how to install connectors on each piece of equipment.

### Motor Plug

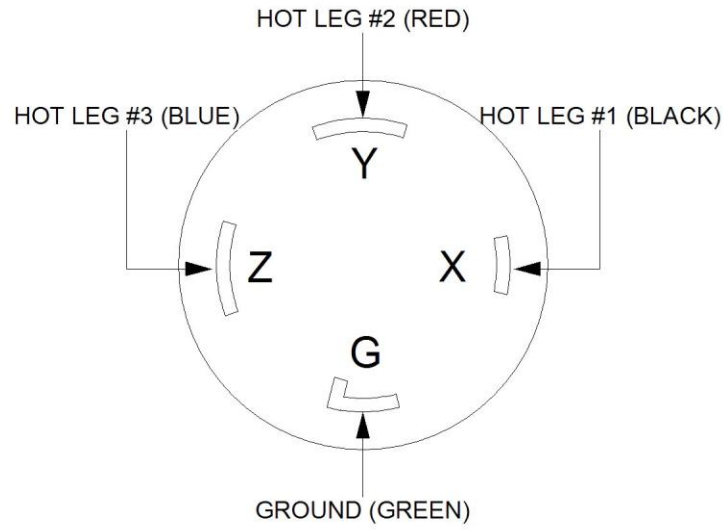

### Brake Plug

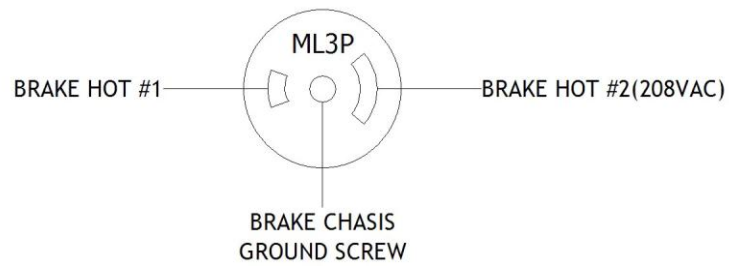

## Limit Plugs

Figure 1.6

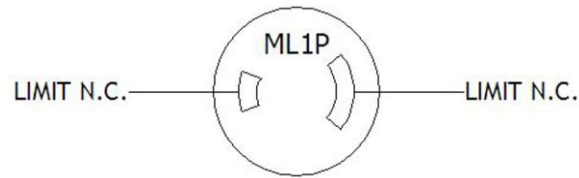

## Encoder Plug

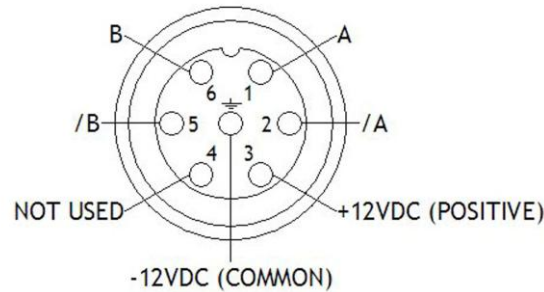

### 1.3.4 Testing a motor

To confirm that your motor is properly connected to the Stagehand AC you should test these conditions:

1. *E-Stop* – Release the E-Stop button on Showstopper. You should hear a “click” from inside the Stagehand AC, this is the E-Stop contactor closing. The LCD display should show that the E-Stop is released by switching the status display to:

Figure 1.11



“Not Connected” indicates that the Stagehand AC is not communicating with a computer running SpikeMark.

2. *Brake release* – Press the **fwd** jog button. You should hear a distinct “click” from your brake. This is the sound of the brake releasing. Release the fwd job button. You should hear a click of the brake engaging.

3. *Motor Motion* – Press the fwd jog button and slowly turn the knob clockwise. The motor should begin moving. Turn the knob counterclockwise to slow the motor to a stop, then release the jog button. Repeat with the rev jog button.
4. *Limit Switches* – Manually activate (or unplug) first the forward limit, then the reverse limit. The LCD display should indicate when a limit is detected.

Figure 1.12



### 1.4 Configuring a Stagehand Network

Many Stagehands can be controlled by a single PC running SpikeMark software. The SpikeMark controls Stagehands through standard network cables and hubs. The following diagram shows a typical network of Stagehands.

Figure 1.13

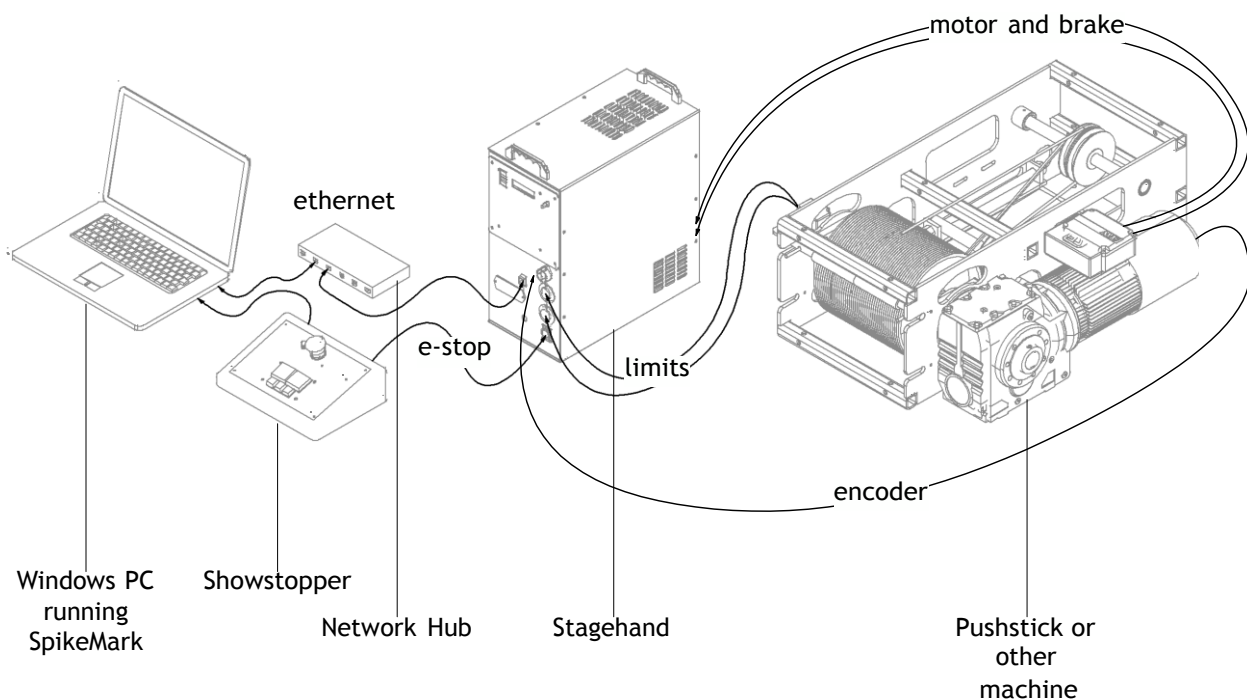

Every component on the network must have a unique IP address. Though you can alter any of the four segments of the Stagehand's IP address, it is often easiest to alter the last number (valid ranges for each segment are 0 to 255). To change the address of a Stagehand, follow these steps:

1. If the E-Stop is engaged, release the E-Stop on Showstopper.
2. Push the knob on the front panel of the Stagehand. The LCD display will change to show that you can edit the IP address.

Figure 1.14



3. By turning the knob, move the cursor over the segment you wish to change. In this example, move the cursor until it is flashing over the number “32”.
4. Press the knob to edit the number “32”.
5. Turn the knob to dial in a new number, for example rotate clockwise until you reach the number “36”.
6. Press the knob to stop editing the number.
7. Rotate the knob until the cursor is flashing on “OK”.
8. Press the knob to accept the changes.

*Note: To discard a changed IP address, you can click on Cancel in step 7.*

## 2 – Using a Stagehand

The Stagehand can be used to drive a motor either manually or through a computer running SpikeMark.

### 2.1 Manual Operation

Using the jog buttons on the face of the Stagehand you can control when the motor stops & starts, and how fast it moves. When moving the motor with the jog controls, **Stagehand** is constantly tracking the position of the motor's encoder. Regardless of whether you move the motor with the jog controls, or with a computer running **SpikeMark**, the motor's position will always be known.

Stagehand will detect limit switches when a motor is moved manually. If a limit switch is hit, **Stagehand** will stop the motor and prevent it from traveling any further in the direction that the limit switch was detected, until the limit switch is released.

*Before moving a motor, make sure that everyone on stage is clear of the motor's path & aware of what is about to move.*

*To move a motor manually:*

1. Press either the **FWD** or **REV** jog button on the face panel.
2. Turn the **knob** clockwise to increase speed.

3. Turn the **knob** counter-clockwise to reduce speed.
4. Release the jog button to stop the motor and engage the brake.

## 2.2 Computer Control with SpikeMark

The real benefit of **Stagehand** is achieved when using it in conjunction with a PC running **SpikeMark** software. **SpikeMark** allows you to program multiple motors to move at specified speeds to exact locations on stage. These moves are written as *cues* and can be edited and run in a similar fashion to a lighting console.

**Stagehand** receives cue information from **SpikeMark** over standard network cables and hubs. **SpikeMark** will inform **Stagehand** where to move, at what speed, and how fast to accelerate. When **SpikeMark** sends a “GO” command, **Stagehand** will begin to move and will guide the motor to the exact position on stage.

In order for Stagehand to know where the motor is at any given time it must receive position information from the motor’s encoder. *If the Stagehand loses power, when it regains power it will reset the encoder position to zero (“0”), regardless of the motor’s actual position.* Should this happen, drive the motor manually to the true zero position (usually the reverse limit switch) and reset the position.

There are two ways to reset position:

1. Cycle power to the Stagehand.

**-OR-**

2. Press the Reset Position button in the SpikeMark software.

To learn more about controlling motors with SpikeMark, refer to your SpikeMark software manual.

## 2.3 Adjust the Stagehand AC Control Output

The **Stagehand AC** is shipped calibrated to produce a motor control signal of 0VDC at 0% output speed. The signal can be adjusted if calibration is lost, or if a voltage bias is required for a particular application. An indication that this signal requires calibration is if the **Drive Configuration Keypad** displays a frequency greater than 0Hz when the **LCD Display** shows 0% in **manual jog mode**. It is possible to adjust this output from the Drive Configuration Keypad (see parameters 4.00-4.12 in the Durapulse manual page 4-5). However, if you cannot achieve the desired result, an internal adjustment can be made.

**To calibrate the bias of the control signal, adjustments must be made with the enclosure open and power applied. It is often easiest to do this adjustment with a co-worker, an extra set of hands can help. As with any power electronics, there is a very real risk of electric shock. Be sure to use insulated tools, and extreme caution. If you are not confident in your ability to make such adjustments, please contact Creative Conners, Inc. and we will arrange to have the calibration done by one of our technicians.**

To adjust the voltage of the motor control signal:

1. Disconnect power from the Stagehand AC.
2. Remove the four black screws from the face cover.



3. **Gently** pull the cover off of the enclosure, rotate it down as if it were hinged along the bottom edge. There is a wiring harness that connects the cover to the base, be careful not to damage the harness.

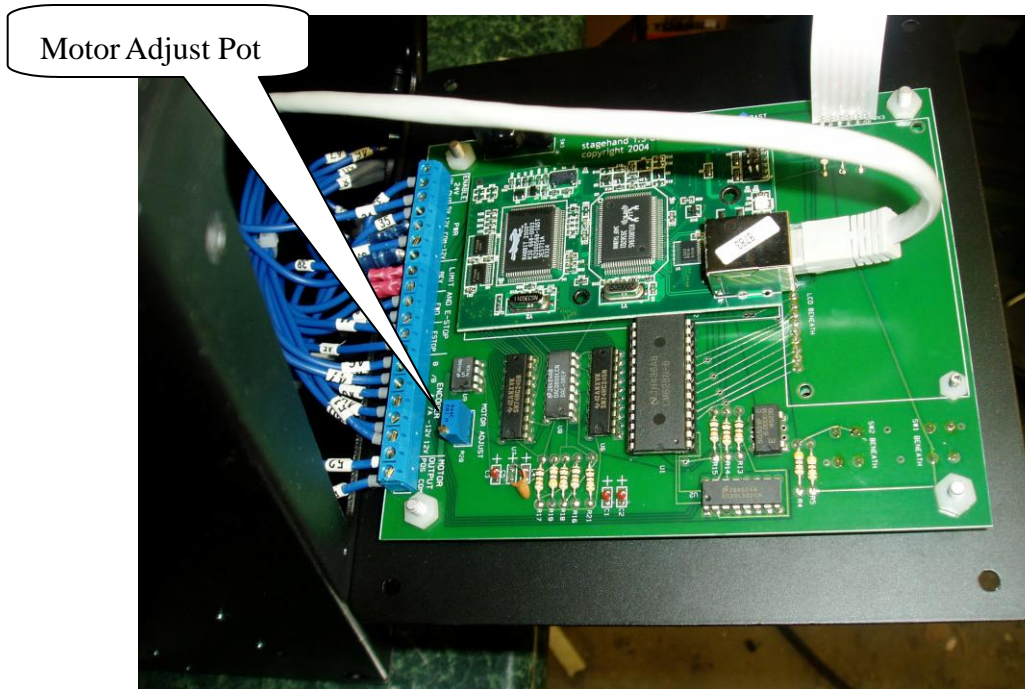

4. With the cover open locate the **Motor Adjust** pot on the back of the cover.
5. Reconnect power to the Stagehand Mini. **Be very careful, there is now line voltage present inside the enclosure.**
6. While pressing either jog button, turn the screw on the **Motor Adjust** pot until the **Drive Configuration Keypad** displays **0.0Hz** .
7. Disconnect power from the **Stagehand AC** and fasten the cover to the enclosure.

### 3 – Troubleshooting

Though the combination of SpikeMark, Stagehand, and Showstopper strives to make automation easy, there are certainly times when things don't work. This part of the guide will give you some earned advice about what to culprits to look for when motors refuse to move.

#### Stagehand lost power and now the position information is incorrect.

Move the motor to the true zero (“0”) position manually and reset the position be either cycling power to the Stagehand, or using the Define Home button in SpikeMark.

#### Motor won't run in cue.

Try moving the motor with the jog controls on the Stagehand.

#### Motor won't run with jog controls.

Check the power being supplied to the Stagehand.

Check the LCD status display on the Stagehand.

- E-Stop! – Either the Showstopper is activated, or the Stagehand isn't connected to the Showstopper so check your cables.
- Forward Limit – The motor is sitting on the limit switch, so you won't be able to move forward. Or the limit switch is unplugged or wired incorrectly. Limit switches need to be wired normally closed (n.c.)
- Reverse Limit – Same as Forward Limit.
- Both Limits – Either you've engaged both limits and need to move one, or the limits aren't plugged in (or they're wired incorrectly).

Meter the voltage coming out of the brake socket, you should see either 120vac or 230vac as soon as you press either jog direction button.

#### Motor runs fine with jog controls, but won't run from SpikeMark.

Check the Stagehand LCD's network status. Connected means it is communicating with your PC, Not Connected means there is either a break in the network cabling or SpikeMark hasn't connected to the Stagehand. Use the Motor Setup to connect to the Stagehand.

Make sure you have a tuning filter loaded. From the Motor Setup>Tuning click Load Filter. If the motor stopped in the middle of a cue and now won't restart, chances are that SpikeMark shut down the motor because it exceeded the Max. Position error. Press the Stop button on Cue Control or Showstopper and then try to reload the cue.

#### When running a cue, the motor speeds fast in the wrong direction and then turns off.

The polarity of the motor is reversed. Open up the motor plug and switch the white and

black wire.

**When running a cue, the motor speeds fast in the right direction and then turns off.**

Check to make sure that the encoder is still attached to the motor securely.

Check the encoder connector.

## Technical Support

Though we try our best to produce reliable software and clear instructions, there may come a time when you need personal support.

### Phone Support

You can call our technical support at 401-862-2980 Monday-Saturday from 8am – 6pm EST. Phone support is free for 90 days, after that a rate of \$30/hr. applies to support calls.

### Web Support

There is an active user support forum on our website. <http://www.creativeconners.com/phpBB3/index.php>

### Email

If you have a technical question you can email technical support [support@creativeconners.com](mailto:support@creativeconners.com).

## 4 – Specifications

### 4.1 Physical Specifications

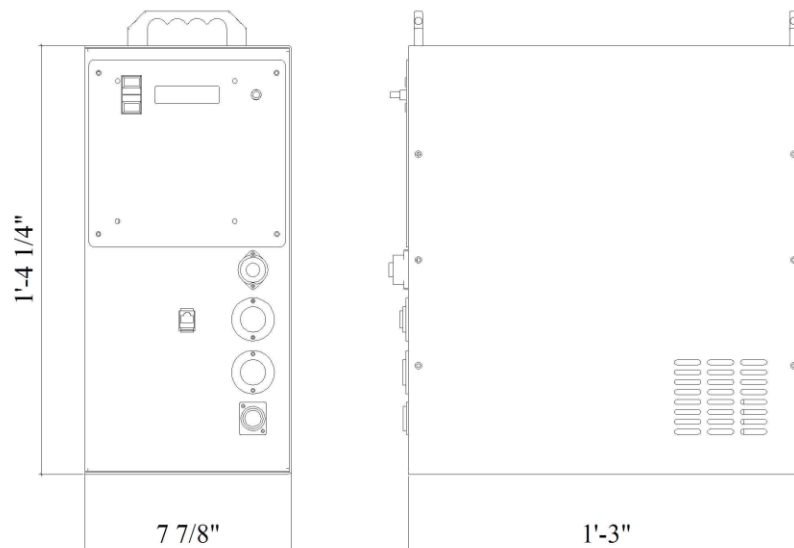

## 4.2 Electrical Specifications

### 208VAC/230VAC model

Input voltage	230V 60Hz 3-phase
Max input current	21 amps
Max output voltage	230VAC variable frequency
Max output horsepower	5hp
Min output horsepower	2hp
Brake output voltage	208V/230V 60Hz
E-Stop input	24VDC
Fwd limit input	N.C. switch
Rev limit input	N.C. switch
Control input	Ethernet RJ45
Encoder input	Quadrature encoder with differential line drivers compatible with 24vdc power supply

## 4.3 Adjusting Mitsubishi Drive Parameters

You can use the keypad on the face of the Stagehand AC to adjust parameters of the internal Mitsubishi A700 inverter. There are many parameters that can be configured, the commonly used parameters are listed in section 4.4. To learn more about other parameters, consult the Mitsubishi A700 manual.

To adjust a parameter on the A700 drive:

1. Press the “Mode” button until the display shows “P.xxx”, where xxx is any number from 0 - 999. Notice that the “Mon” light goes out, indicating that you are no longer monitoring the motor.
2. Use the scroll wheel to find the parameter you want to adjust (eg. “P. 1”)
3. Press the “Set” key.
4. The current setting for the selected parameter will be displayed.
5. Use the scroll wheel to adjust the setting.
6. Press “Set” to accept the new parameter value or “Mode” to escape and leave the parameter unchanged.
7. When you are finished setting parameters, press “Mode” until the “Mon” light illuminates indicating that keypad is monitoring the motor.

## 4.4 Default Mitsubishi Drive Parameters

Settings for Mitsubishi A700 drive			
Parameter Code	Description	Value	Description
1	Maximum Frequency	120Hz	max output frequency
7	Acceleration time	0	
8	Deceleration time	0	0 seconds
9	Motor full load amps	17	
13	Starting frequency	0.5	Motor won't start until the speed signal is at least this value.
30	Regenerative function	1	External brake resistor, L1/L2/L3 power source
70	Regenerative brake duty	10%	duty cycle of the braking resistor
71	Motor type	3	Other mfg. standard motor
72	Carrier frequency	15	Reduces output noise
73	Analog input selection	14	+/-10vdc with reversing enabled
77	Parameter write selection	2	allow parameter writes regardless of operation status
79	Control mode	2	Keypad disabled, external control
80	Motor capacity	3.7	kilowatts
81	Motor poles	4	
83	Motor voltage	230V	
84	Motor rated frequency	60Hz	
196	Relay #2 output	0	Brake released when drive is running
252	Override bias	100%	Percentage of analog signal to use for speed signal ***adjust this to overspeed motor
800	Control method	10	Real sensorless vector control, speed control
C15	Terminal 1 Gain Frequency	112%	gain increase for analog speed signal input (adjusted since input is really only 8.8vdc)

## 4.5 Drive Auto-Tuning

The Mitsubishi A700 series inverter is capable of great low-speed and zero-speed torque. Depending on the demands of your machinery and your requirements for torque, you may need to fine-tune the inverter for your specific motor. The A700 inverter can perform an auto-tuning sequence to calibrate the drive for optimal performance with your motor. Follow these steps to auto-tune your motor when the motor is installed in a machine:

1. Make sure the Showstopper emergency stop signal is released.
2. Set Parameter 9 equal to the rated current of the motor.
3. Set Parameter 83 equal to the rated voltage of the motor.
4. Confirm that Parameter 71 is set to 3. This informs the drive that a general purpose motor is being used.
5. Set Parameter 96 to "1". This tells the drive to execute a tuning cycle without moving the motor.
6. Press the **Mode** button on the keypad twice, it should display a "1" without flashing.

7. Press and hold the FWD jog button on the Stagehand face (not the drive keypad) to start the tuning process, you must continue to hold button until the drive completes the tuning.

During the tuning process the keypad displays “2”. If it completes successfully, the keypad will display “3”. If there was an error, the keypad displays “9”. For more information see the Mitsubishi A700 series manual starting at page 190.

*Please note that this tuning procedure does not eliminate the need for tuning filters in SpikeMark, for more on SpikeMark's tuning process consult the SpikeMark manual.*