

creative conners, inc.

Stagehand DC Reference Manual

Version 1.0

Table of Contents

Stagehand™ DC Reference Manual3

1 – Getting Started3

 1.1 What’s in the box?.....3

 1.2 Stagehand DC Overview.....3

 1.3 Installing Stagehand.....8

 1.3.1 Mounting Stagehand.....8

 1.3.2 Hooking up power.....9

 1.3.3 Hooking up a motorized effect12

 1.3.4 Testing a motor.....14

 1.4 Configuring a Stagehand Network15

2 – Using a Stagehand.....16

 2.1 Manual Operation16

 2.2 Computer Control with Avista.....17

3 – Troubleshooting18

 Stagehand lost power and now the position information is
 incorrect.....18

 Motor won’t run in cue.....18

 Motor won’t run with jog controls.....18

 Motor runs fine with jog controls, but won’t run from Avista. .19

 When running a cue, the motor speeds fast in the wrong
 direction and then turns off.19

 When running a cue, the motor speeds fast in the right direction
 and then turns off.19

 Technical Support20

 Phone Support.....20

 Web Support.....20

 Email.....20

4 – Specifications20

 4.1 Physical Specifications.....20

 4.2 Electrical Specifications21

Stagehand™ DC Reference Manual

1 – Getting Started

Congratulations on your purchase of the Stagehand DC scenic motion controller from Creative Conners, Inc. Stagehand DC brings the excitement of automation to theatres of all sizes. Stagehand DC is a unique combination of motion controller and motor drive that eliminates the clutter and complexity of other automation systems.

This manual will direct you through:

1. Unpacking
2. Installing & testing
3. Operation procedures

If you need help along the way contact us either on our website (www.creativeconners.com), via email (support@creativeconners.com), or by phone (401.862.2980)

1.1 What's in the box?

Inside the box you should find:

1. Reference manual (this document)
2. Stagehand DC motion controller
3. 7-pin encoder connector

If any of these items are missing, please contact us immediately for a replacement.

If you purchased any power cables, encoders, limit switches, or other accessories, those items are packaged separately.

1.2 Stagehand DC Overview

The Stagehand DC performs two major functions: motion control and power amplification. This means that Stagehand can:

1. Track the position of a motor that is equipped with a quadrature encoder.
2. Control the speed, acceleration, and position of a motor that is equipped with a quadrature encoder.
3. Supply the power necessary to move the motor.

Typically these functions have been divided between two or more pieces of equipment, but Stagehand packs all of this functionality into one convenient box.

After unpacking your Stagehand DC, take a moment to familiarize yourself with its various connections and features.

Figure 1.1



Figure 1.1 shows the connections located on the top of the Stagehand DC. From left to right, top to bottom, these connections are:

1. **Motor Power** – The motor power receptacle is a NEMA midget connector (ML2). This receptacle supplies DC power for your motor at either 180VDC or 90VDC, depending on the model ordered.
2. **Brake Power** – The brake power receptacle is a NEMA midget connector (ML3). This receptacle supplies AC power for your spring-set brake at either 208/230VAC or 115VAC depending on the model ordered.
3. **FWD Limit** – The forward limit receptacle is a NEMA midget connector (ML1). This receptacle is used to connect a limit switch that will detect the end of forward travel for your machine. The limit should be wired as normally closed switch (N.C.).
4. **REV Limit** – The reverse limit receptacle is a NEMA midget connector (ML1). This receptacle is used to connect a limit switch that will detect the end of reverse travel for your

machine. The limit should be wired as normally closed switch (N.C.).

5. **Ethernet** – The Ethernet receptacle accepts a standard RJ45 network cable. Stagehand DC uses Ethernet as the control protocol to communicate with a PC running Avista™ software.
6. **Encoder** – The encoder receptacle is a Amphenol T3107 000 connector. This receptacle provides power (24VDC) to, and receives position information from, a quadrature encoder.
Note: The encoder allows Stagehand to track a motor's position.
7. **E-Stop** – The E-Stop (a.k.a. emergency stop) receptacle is a 5-pin XLR connector. This receptacle receives a dedicated emergency signal (24VDC) from a Showstopper base station. If this signal is present, the Stagehand is free to move, when the signal is interrupted it will immediately remove power from the motor

Figure 1.2

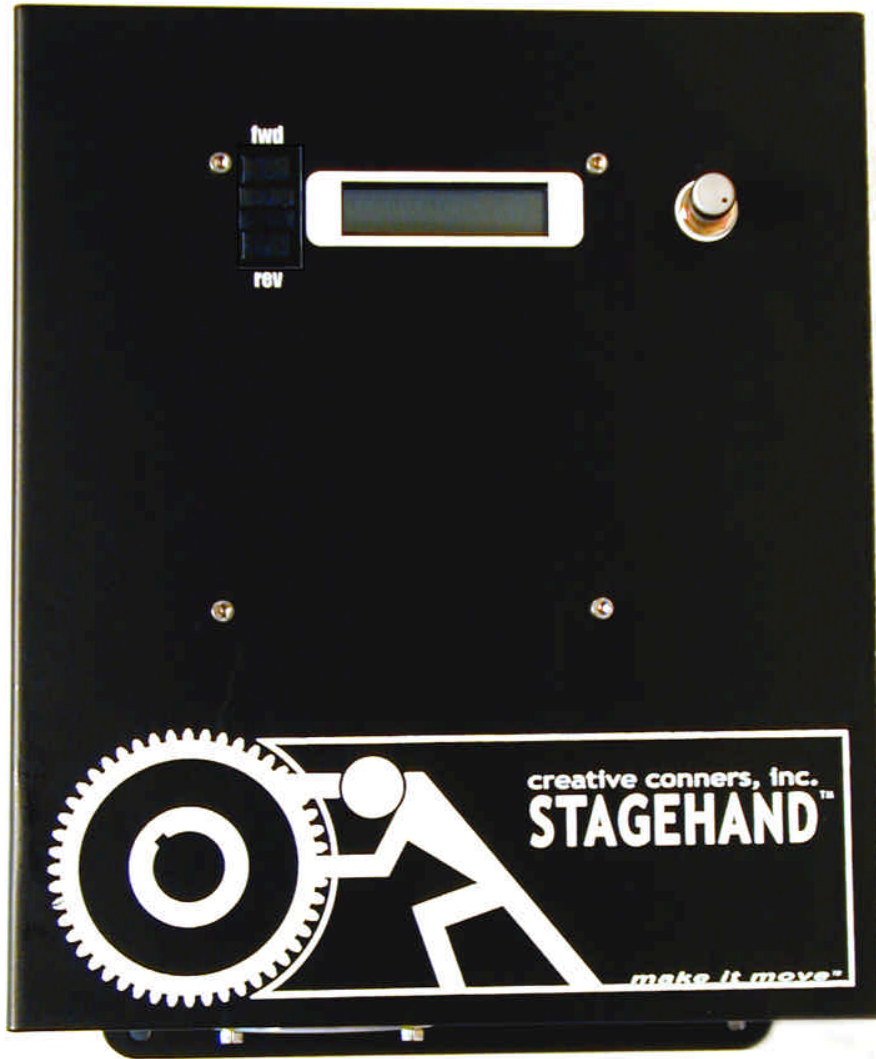

Figure 1.2 shows the controls located on the front of the Stagehand DC. From left to right, top to bottom, the controls are:

1. **Forward jog button** – When pressed the Stagehand will switch to manual operation, and begin to jog in the forward direction.
2. **Reverse jog button** – When pressed the Stagehand will switch to manual operation, and begin to jog in the reverse direction.
3. **LCD Display** – The display shows information about the Stagehand's status. When idle, it shows the current IP address

and the status of the network connection between the **Stagehand** and a PC running **Avista**. If a limit switch or E-Stop has been activated, the condition will be displayed. In jog mode, it will display the jog direction and speed. In address mode, it will let you alter the current IP address.

4. **Knob** – The **knob** performs different functions depending on the function being performed:
 - a. If either **jog button** is pressed, the **knob** will function as a speed dial.
 - b. To set the IP address, press the **knob** (it's also a button) and then turn the **knob** to adjust the address.

Figure 1.3

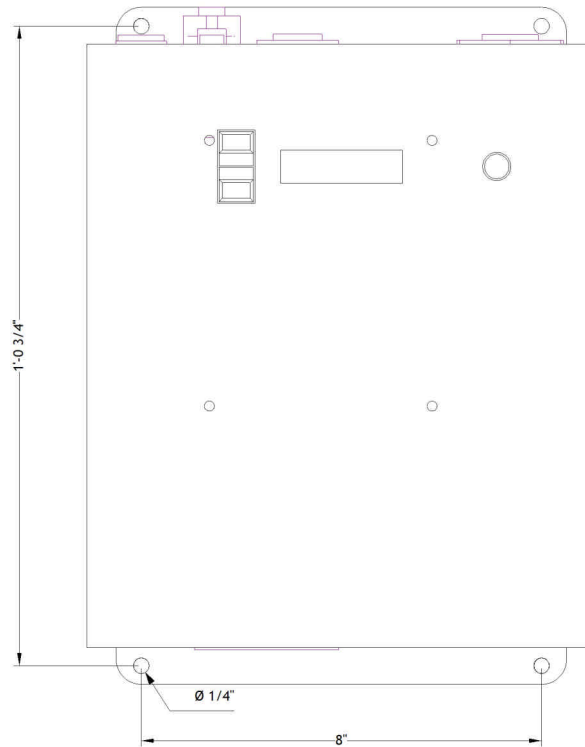

Figure 1.3 shows the power inlet located on the bottom of the Stagehand DC. This is a NEMA L6-20 connector (for 208/230vac models) or a NEMA L5-20 connector (for 120vac models).

1.3 Installing Stagehand

1.3.1 Mounting Stagehand

Figure 1.4



The Stagehand DC has four mounting holes, as shown in Figure 1.4, that can be used to mount the panel to a wall or portable stand. The Stagehand should be mounted in a location that is moderate in temperature (40°F-90°F) as well as free from excessive dust and moisture.

Typically, it is best to mount the Stagehand DC within 6' of the motor it controls. This reduces cable clutter and minimizes the risk of electrical interference (both RFI & EMI). Longer distances are possible with motor, encoder, and limit cable extensions.

1.3.2 Hooking up power

Stagehand needs power to store a motor's position information & to drive a motor. **Care should be taken to power the Stagehand from a source that is not likely to be interrupted. If power is lost to a Stagehand, the motor's position information will be reset to zero (0), regardless of the motor's actual position.**

208/230vac models of the Stagehand DC should be connected with a NEMA L6-20 cord-style receptacle that is wired as shown:

Figure 1.5

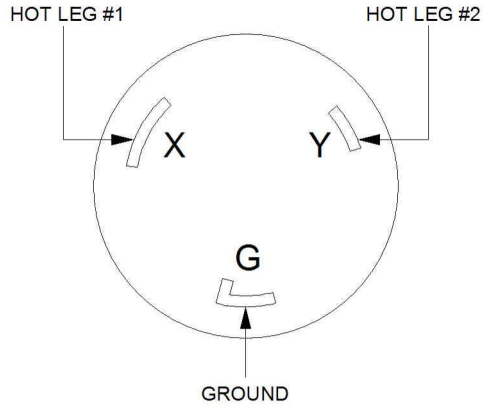

120vac models of the Stagehand DC should be connected with a NEMA L5-20 cord-style receptacle that is wired as shown:

Figure 1.6

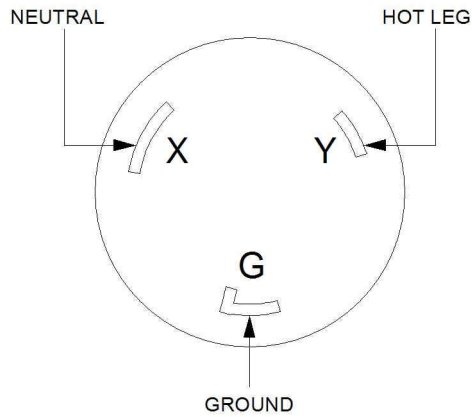

To reduce the risk of fire and equipment damage, Stagehand DC's should be installed with proper branch circuit protection. There are two recommended methods for protecting a Stagehand from excessive current; either may be employed depending on other installation requirements.

1. Install a properly sized circuit breaker on the dedicated circuit supplying power to the Stagehand. See figure 1.8 for breaker sizing.

-OR-

2. Install properly sized fuses inside the Stagehand DC. There are line fuses located within the Stagehand DC that protect the motor amplifier from over-current damage. The amplifier is shipped with 20amp, 1/4"x1 1/4" AGC fuses. These fuses are sized for the maximum rating of the amplifier (2 hp), but can be reduced to protect smaller motors from damage. To replace these fuses follow these steps:
 - a. Disconnect power from the Stagehand DC.
 - b. Remove the 8 screws on the left & right sides of the enclosure.
 - c. Gently pull the cover off, taking care not to damage the wire harness that runs between the cover and the base of the enclosure.
 - d. Locate the two (2) fuses on the motor amplifier as shown in figure 1.7 and replace them with the proper fuses from Figure 1.8.

Figure 1.7

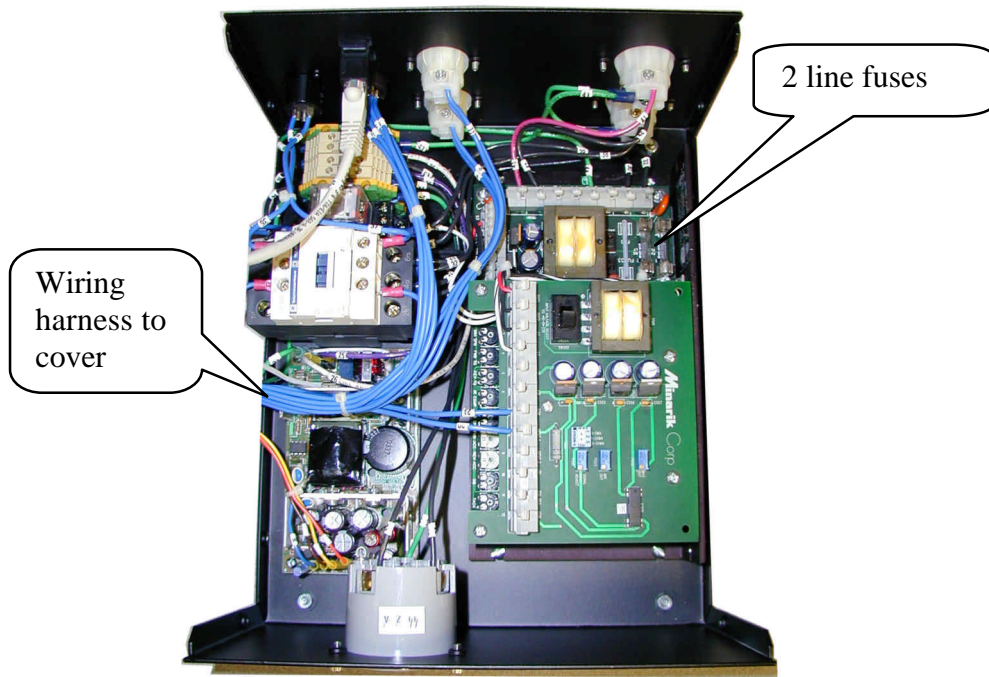

Figure 1.8

90 VDC Motor HP (120VAC input)	180 VDC Motor HP (208/230vac input)	AC Line Fuse (amps)
1/4	1/2	8
1/3	3/4	8
1/2	1	10
3/4	1 1/2	15
1	2	20

Once you have applied power, the LCD display should light up and display the following (note: IP address may be different).

Figure 1.9



The “E-Stop!!” message is displayed because you have not yet hooked up the Stagehand with Showstopper. If the Stagehand does not detect a signal from Showstopper, it will assume an Emergency Stop condition.

The number on the bottom line of the display is the Stagehand’s IP address. We’ll look at changing the IP address in section 1.4.

1.3.3 Hooking up a motorized effect

If you are using a **Pushstick** or other motorized effect from Creative Conners, making connections to the **Stagehand DC** is easy. With the **Showstopper** E-Stop engaged:

1. Connect the encoder to the **encoder socket**.
2. Connect the brake to the **brake socket**.
3. Connect the motor to the **motor socket**.
4. Connect either the forward limit or a limit jumper to the **forward limit socket**. *Note: A limit jumper is a MLI plug that has a wire connected between the two pins on the plug. This will simulate a normally closed limit switch, thus allowing travel in the forward direction.*
5. Connect either the reverse limit or a limit jumper to the **reverse limit socket**.
6. Using a network cable (RJ45 Cat5), connect the **Ethernet socket** to an Ethernet hub.
7. Using a **Showstopper cable** (5-pin XLR) connect the **Showstopper** to the **E-Stop** inlet on the **Stagehand DC**.

If you are using your own motorized effect, you will need to install connectors on your devices prior to connecting to the **Stagehand DC**.

The following diagrams show how to install connectors on each piece of equipment.

Figure 1.10

Motor Plug

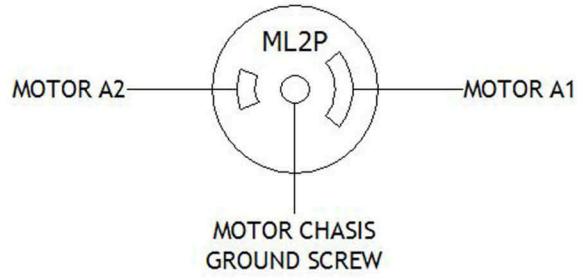

Brake Plug

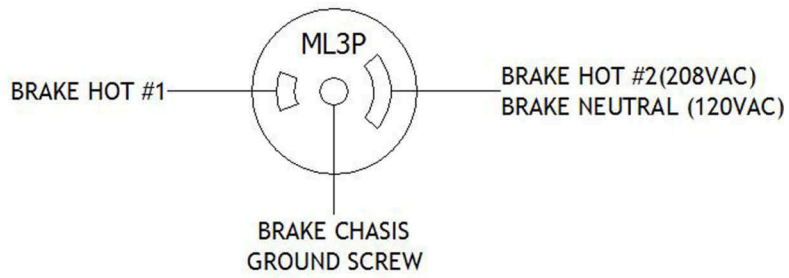

Limit Plugs

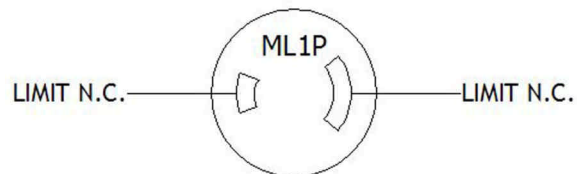

Encoder Plug

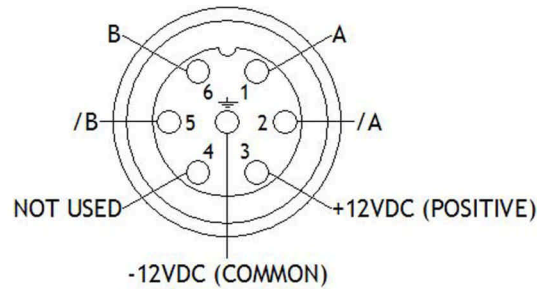

1.3.4 Testing a motor

To confirm that your motor is properly connected to the Stagehand DC you should test these conditions:

1. *E-Stop* – Release the E-Stop button on Showstopper. You should hear a “click” from inside the Stagehand DC, this is the E-Stop contactor closing. The LCD display should show that the E-Stop is released by switching the status display to:

Figure 1.11



“Not Connected” indicates that the Stagehand DC is not communicating with a computer running Avista.

2. *Brake release* – Press the **fwd** jog button. You should hear a distinct “click” from your brake. This is the sound of the brake releasing. Release the fwd jog button. You should hear a click of the brake engaging.
3. *Motor Motion* – Press the fwd jog button and slowly turn the knob clockwise. The motor should begin moving. Turn the knob counterclockwise to slow the motor to a stop, then release the jog button. Repeat with the rev jog button.

4. *Limit Switches* – Manually activate (or unplug) first the forward limit, then the reverse limit. The LCD display should indicate when a limit is detected.

Figure 1.12



1.4 Configuring a Stagehand Network

Many Stagehands can be controlled by a single PC running Avista software. The Avista controls Stagehands through standard network cables and hubs. The following diagram shows a typical network of Stagehands.

Figure 1.13

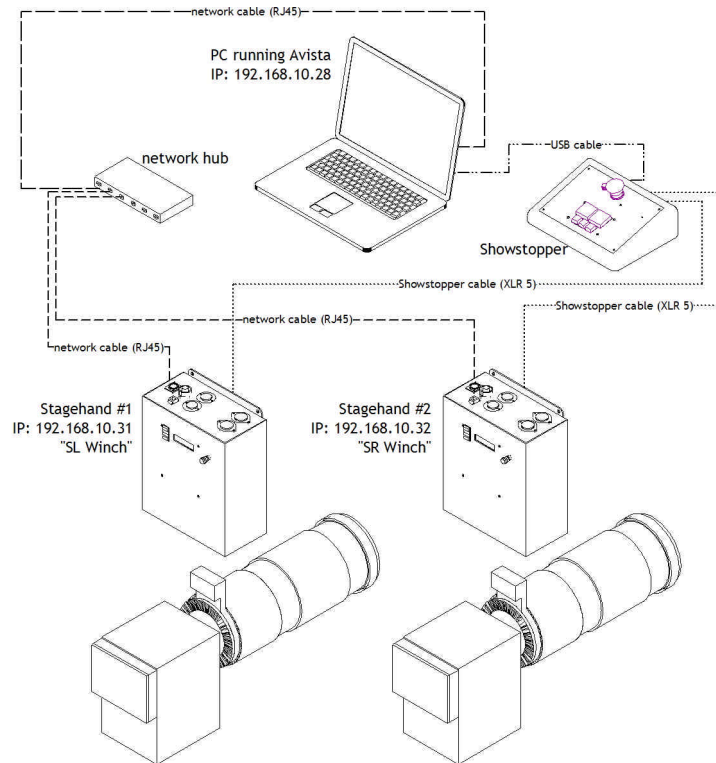

Every component on the network must have a unique IP address. Though you can alter any of the four segments of the Stagehand's IP address, it is often easiest to alter the last number (valid ranges for each segment are 0 to 255). To change the address of a Stagehand, follow these steps:

1. If the E-Stop is engaged, release the E-Stop on Showstopper.
2. Push the knob on the front panel of the Stagehand. The LCD display will change to show that you can edit the IP address.

Figure 1.14



3. By turning the knob, move the cursor over the segment you wish to change. In this example, move the cursor until it is flashing over the number "32".
4. Press the knob to edit the number "32".
5. Turn the knob to dial in a new number, for example rotate clockwise until you reach the number "36".
6. Press the knob to stop editing the number.
7. Rotate the knob until the cursor is flashing on "OK".
8. Press the knob to accept the changes.

Note: To discard a changed IP address, you can click on Cancel in step 7.

2 – Using a Stagehand

The Stagehand can be used to drive a motor either manually or through a computer running Avista.

2.1 Manual Operation

Using the jog buttons on the face of the Stagehand you can control when the motor stops & starts, and how fast it moves. When moving the motor with the jog controls, **Stagehand** is constantly tracking the position of the motor's encoder. Regardless of whether you move the

motor with the jog controls, or with a computer running **Avista**, the motor's position will always be known.

Stagehand will detect limit switches when a motor is moved manually. If a limit switch is hit, **Stagehand** will stop the motor and prevent it from traveling any further in the direction that the limit switch was detected, until the limit switch is released.

Before moving a motor, make sure that everyone on stage is clear of the motor's path & aware of what is about to move.

To move a motor manually:

1. Press either the **FWD** or **REV** jog button on the face panel.
2. Turn the **knob** clockwise to increase speed.
3. Turn the **knob** counter-clockwise to reduce speed.
4. Release the jog button to stop the motor and engage the brake.

2.2 Computer Control with Avista

The real benefit of **Stagehand** is achieved when using it in conjunction with a PC running **Avista** software. **Avista** allows you to program multiple motors to move at specified speeds to exact locations on stage. These moves are written as *cues* and can be edited and run in a similar fashion to a lighting console.

Stagehand receives cue information from **Avista** over standard network cables and hubs. **Avista** will inform **Stagehand** where to move, at what speed, and how fast to accelerate. When **Avista** sends a "GO" command, **Stagehand** will begin to move and will guide the motor to the exact position on stage.

In order for Stagehand to know where the motor is at any given time it must receive position information from the motor's encoder. ***If the Stagehand loses power, when it regains power it will reset the encoder position to zero ("0"), regardless of the motor's actual position.*** Should this happen, drive the motor manually to the true zero position (usually the reverse limit switch) and reset the position. There are two ways to reset position:

1. Cycle power to the Stagehand.

-OR-

2. Press the Define Home button in the Avista software.

To learn more about controlling motors with Avista, refer to your Avista software manual.

3 – Troubleshooting

Though the combination of Avista, Stagehand, and Showstopper strives to make automation easy, there are certainly times when things don't work. This part of the guide will give you some earned advice about what to culprits to look for when motors refuse to move.

Stagehand lost power and now the position information is incorrect.

Move the motor to the true zero ("0") position manually and reset the position be either cycling power to the Stagehand, or using the Define Home button in Avista.

Motor won't run in cue.

Try moving the motor with the jog controls on the Stagehand.

Motor won't run with jog controls.

Check the power being supplied to the Stagehand.

Check the LCD status display on the Stagehand.

- E-Stop! – Either the Showstopper is activated, or the Stagehand isn't connected to the Showstopper so check your cables.
- Forward Limit – The motor is sitting on the limit switch, so you won't be able to move forward. Or the limit switch is unplugged or wired incorrectly. Limit switches need to be wired normally closed (n.c.)
- Reverse Limit – Same as Forward Limit.
- Both Limits – Either you've engaged both limits and need to move one, or the limits aren't plugged in (or they're wired incorrectly).

Meter the voltage coming out of the Motor Power socket on the Stagehand as you use the jog controls. If you have a 120vac input you should see 90vdc output, 230vac input you should see 180vdc output.

Meter the voltage coming out of the brake socket, you should see either 120vac or 230vac as soon as you press either jog direction button.

If you aren't getting motor voltage, check the internal fuses in the Stagehand (see Stagehand owner's manual for details)

Motor runs fine with jog controls, but won't run from Avista.

Check the Stagehand LCD's network status. Connected means it is communicating with your PC, Not Connected means there is either a break in the network cabling or Avista hasn't connected to the Stagehand. Use the Motor Setup to connect to the Stagehand.

Make sure you have a tuning filter loaded. From the Motor Setup>Tuning click Load Filter.

If the motor stopped in the middle of a cue and now won't restart, chances are that Avista shut down the motor because it exceeded the Max. Position error. Press the Stop button on Cue Control or Showstopper and then try to reload the cue.

When running a cue, the motor speeds fast in the wrong direction and then turns off.

The polarity of the motor is reversed. Open up the motor plug and switch the white and black wire.

When running a cue, the motor speeds fast in the right direction and then turns off.

Check to make sure that the encoder is still attached to the motor securely.

Check the encoder connector.

Technical Support

Though we try our best to produce reliable software and clear instructions, there may come a time when you need personal support.

Phone Support

You can call our technical support at 401-862-2980 Monday-Saturday from 8am – 6pm EST. Phone support is free for 90 days, after that a rate of \$30/hr. applies to support calls.

Web Support

There is an active user support forum on our website.

<http://www.creativeconners.com/phpBB2/index.php>

Email

If you have a technical question you can email technical support support@creativeconners.com.

4 – Specifications

4.1 Physical Specifications

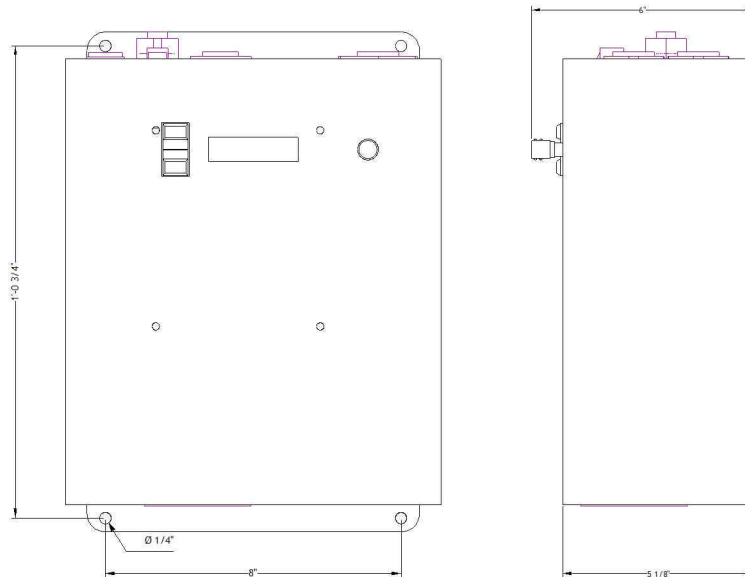

4.2 Electrical Specifications

208VAC/230VAC model

Input voltage	208V/230V 60Hz
Max input current	20 amps
Max output voltage	180VDC
Max output horsepower	2hp
Min output horsepower	1hp
Brake output voltage	208V/230V 60Hz
E-Stop input	24VDC
Fwd limit input	N.C. switch
Rev limit input	N.C. switch
Control input	Ethernet RJ45
Encoder input	Quadrature encoder with differential line drivers compatible with 24vdc power supply

120VAC model

Input voltage	120V 60Hz
Max input current	20 amps
Max output voltage	90VDC
Max output horsepower	1hp
Min output horsepower	¼ hp
Brake output voltage	120V 60Hz
E-Stop input	24VDC
Fwd limit input	N.C. switch
Rev limit input	N.C. switch
Control input	Ethernet RJ45
Encoder input	Quadrature encoder with differential line drivers compatible with 24vdc power supply