

creative conners, inc.

# Pushstick Reference Manual

Version 1.0

Copyright © 2004. Creative Conners, Inc. All rights reserved.

**Table of Contents**

**Pushstick Reference Manual .....3**

**1 – Getting Started.....3**

    1.1 A word about safety .....3

    1.2 Pushstick Overview.....4

    1.3 Installing Pushstick .....6

        1.3.1 Mounting the Pushstick .....6

        1.3.3 Connecting Pushstick to a Stagehand.....7

        1.3.4 Testing a motor.....7

**2 – Rigging a Pushstick.....8**

**3 – Troubleshooting ..... 10**

    Motor is jerky..... 10

    Idler pulleys aren’t tracking as the cable moves..... 10

    When running a cue, the motor speeds fast in the wrong direction and then turns off..... 10

    When running a cue, the motor speeds fast in the right direction and then turns off. .... 10

    Technical Support ..... 11

        Phone Support..... 11

        Web Support ..... 11

        Email ..... 11

**4 – Specifications..... 12**

    4.1 Physical Specifications..... 12

    4.2 Specifications ..... 13

# Pushstick Reference Manual

## 1 – Getting Started

Congratulations on your purchase of the **Pushstick** deck winch from Creative Conners, Inc. **Pushstick** is winch designed to meet the demands of scenic automation.

This manual will direct you through:

1. Unpacking
2. Installing & testing
3. Operation procedures

If you need help along the way contact us either on our website ([www.creativeconners.com](http://www.creativeconners.com)), via email ([support@creativeconners.com](mailto:support@creativeconners.com)), or by phone (401.862.2980)

### ***1.1 A word about safety***

The **Pushstick** winch is a fantastic machine for moving scenery. With great ease, it will pull large, heavy sets across the stage. Such power deserves a great degree of respect, as it can also represent a very serious hazard if misused. Proper deck rigging practices should always be understood and employed when installing a **Pushstick** winch.

**Pushstick winches are not intended for overhead lifting.** The **Pushstick** is constructed to be a rugged and versatile deck winch, used for deck tracks, traveler tracks, and other lateral motion applications.

Each **Pushstick** winch comes with a label indicating its maximum pulling capacity. This rating is the maximum line pull that can be generated by the winch's motor and gearbox.

## 1.2 Pushstick Overview

The **Pushstick** winch is built to be easy to use and tough enough to withstand the rigors of any show. Depending on the model purchased, the **Pushstick** comes with either a 2hp DC, 2hp AC, or 5hp AC motor. All **Pushstick** winches come equipped with the following components (shown in Figure 1.1):

1. Motor
2. Spring-set brake
3. Incremental encoder
4. Speed reducer
5. 12" grooved drum
6. Delrin keeper roller
7. Rotary limit switch
8. Idler sheaves
9. Tension sheaves

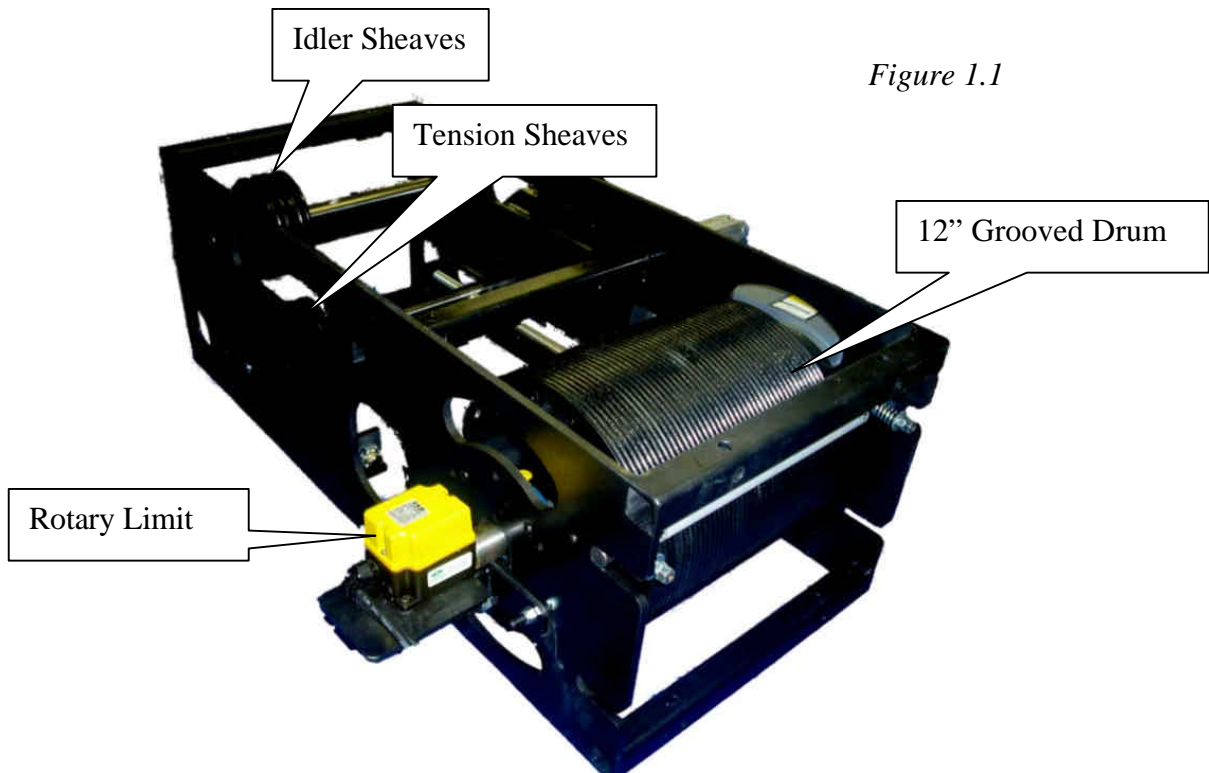

*Figure 1.1*

Figure 1.2

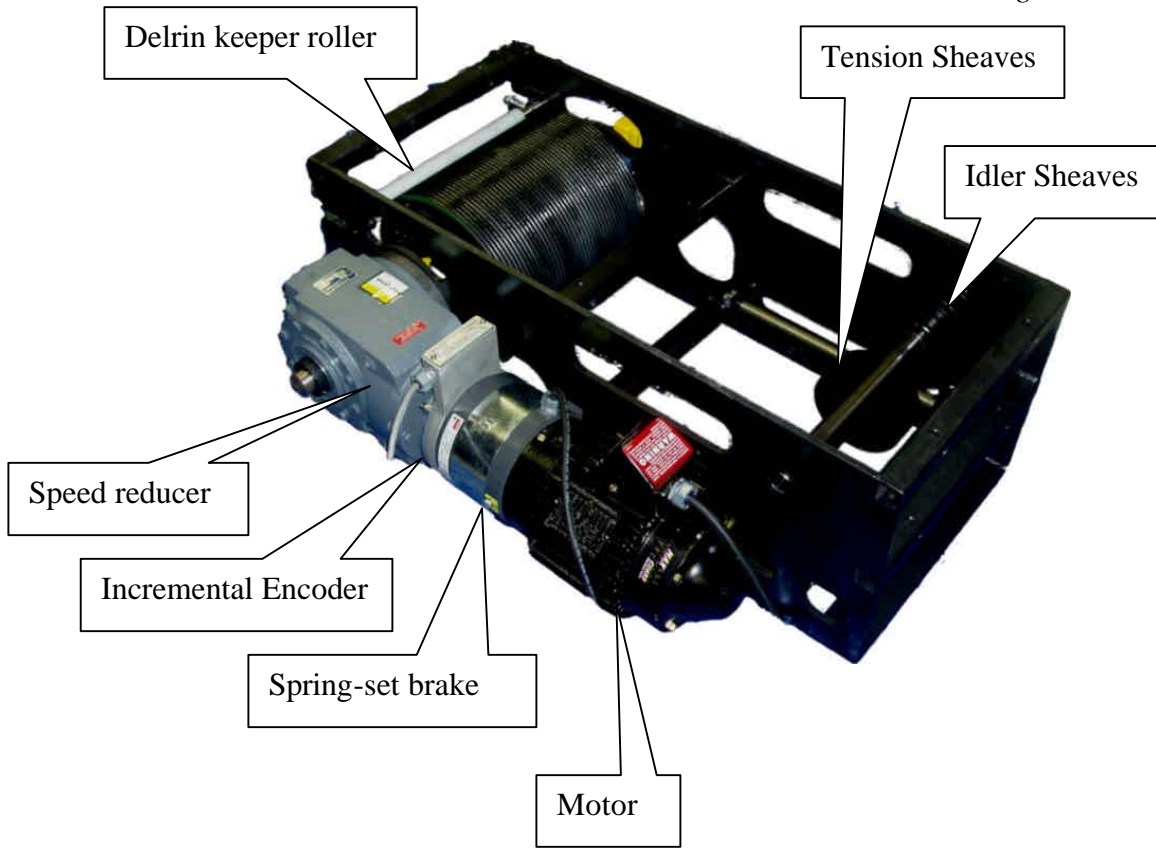

## 1.3 Installing Pushstick

### 1.3.1 Mounting the Pushstick

Figure 1.3

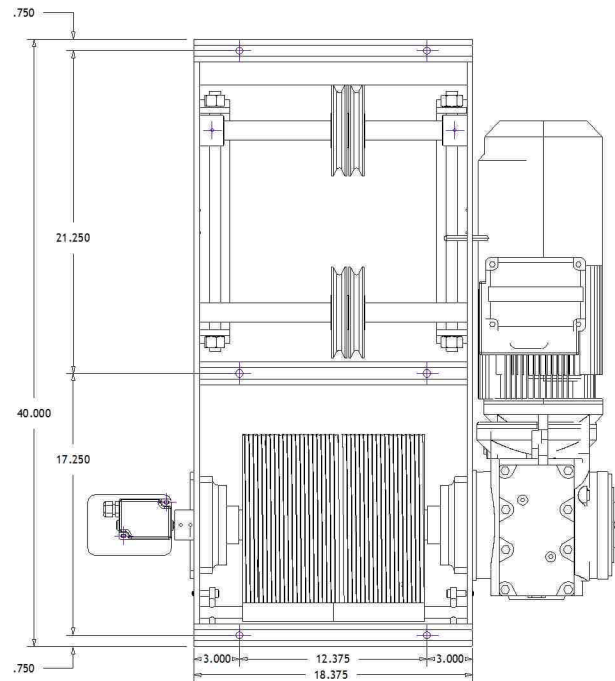

The **Pushstick** winch is designed to be mounted either horizontally or vertically, depending on the application. There are numerous mounting holes on all sides of the **Pushstick** frame that may be used to bolt the winch to any solid structure.

The primary concern when mounting a **Pushstick** is to insure that when the winch exerts maximum pull, the scenery moves and the winch does not. To help keep the winch from pulling free of its

mounting, additional bracing may be used between the **Pushstick** and the first series of diverter pulleys. This bracing is also called “bucking”.

### 1.3.3 Connecting Pushstick to a Stagehand

Prior to attaching the **Pushstick** to a piece of scenery, you should confirm proper winch operation. To test the winch operation you will need a Stagehand controller (refer to your Stagehand manual for installation instructions). With the Stagehand installed, make the following connections between the **Pushstick** and Stagehand:

1. Connect the encoder to the **encoder socket**.
2. Connect the brake to the **brake socket**.
3. Connect the motor to the **motor socket**.
4. Connect either the forward limit or a limit jumper to the **forward limit socket**. *Note: A limit jumper is a MLI plug that has a wire connected between the two pins on the plug. This will simulate a normally closed limit switch, thus allowing travel in the forward direction.*
5. Connect either the reverse limit or a limit jumper to the **reverse limit socket**.
6. Using a network cable (RJ45 Cat5), connect the **Ethernet socket** to an Ethernet hub.
7. Using a **Showstopper cable** (5-pin XLR) connect the **Showstopper** to the **E-Stop** inlet on the **Stagehand AC**.

### 1.3.4 Testing a motor

To confirm that your motor is properly connected to the Stagehand you should test these conditions:

1. *E-Stop* – Release the E-Stop button on Showstopper. You should hear a “click” from inside the Stagehand, this is the E-Stop contactor closing. The LCD display should show that the E-Stop is released by switching the status display to:

*Figure 1.11*



“Not Connected” indicates that the Stagehand is not communicating with a computer running Avista.

2. *Brake release* – Press the **fwd** jog button. You should hear a distinct “click” from your brake. This is the sound of the brake releasing. Release the fwd job button. You should hear a click of the brake engaging.
3. *Motor Motion* – Press the fwd jog button and slowly turn the knob clockwise. The motor should begin moving. Turn the knob counterclockwise to slow the motor to a stop, then release the jog button. Repeat with the rev jog button.
4. *Limit Switches* – Manually activate (or unplug) first the forward limit, then the reverse limit. The LCD display on the Stagehand should indicate when a limit is detected.

*Figure 1.12*



## 2 – Rigging a Pushstick

Once you have confirmed that the winch is working properly without a load attached, the winch can be rigged. As a versatile machine, the **Pushstick** can be rigged in a variety of ways depending on your specific application. In this manual a typical process for rigging the **Pushstick** as a deck winch is explained. Figure 2.1 shows a schematic diagram of a typical deck winch rig.

*Figure 2.1*

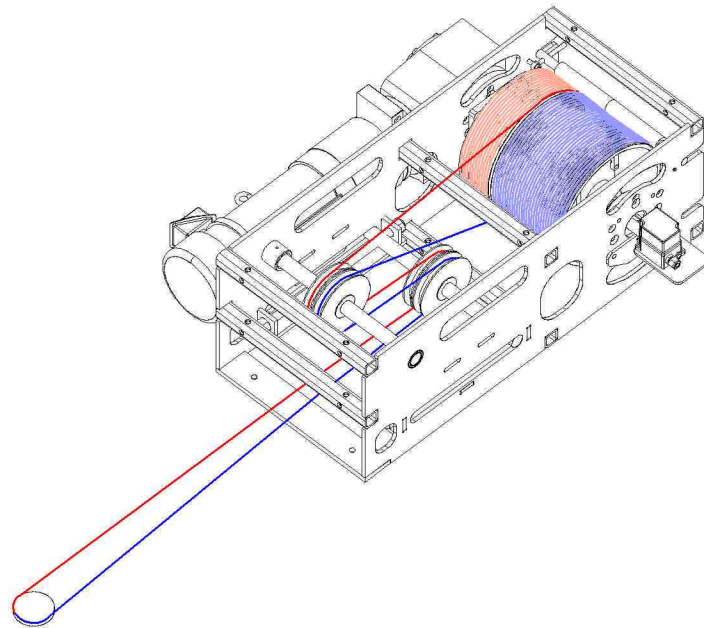

1. Place a spool of wire rope (often either  $\frac{3}{16}$ " or  $\frac{1}{4}$ " ) next to the **Pushstick**.
2. Turn the threaded rods on the tension pulleys until the tension pulleys are completely towards the front of the winch (away from the drum).
3. Take the end of the wire rope from the spool and run it through your deck sheaves and eventually back to the winch.
4. Terminate the end of the wire rope by slipping it through a hole in the grooved drum and clamping it down with the clamps inside the grooved drum. The clamps have notches for  $\frac{1}{4}$ " cable, if using a different size cable simply position the cable between the notches before tightening the clamp.
5. Using the Stagehand, slowly move the motor with the manual controls. The cable should begin to wind up onto the drum.
6. When the drum is mostly full of cable (approximately 6" of bare drum) stop the motor.
7. Cut the wire rope with 10' of extra length. Wrap the cable around the bare end of the drum three times and terminate the

cut end of the wire rope into the drum. There should be approximately 2” of bare drum between the cables.

8. Turn the threaded rods on the tension pulleys to move the pulleys towards the drum and tighten the cables.

Your **Pushstick** winch is now ready to move scenery!

### **3 – Troubleshooting**

Though the combination of **Pushstick**, Avista, Stagehand, and Showstopper strives to make automation easy, there are certainly times when things don’t work. This part of the guide will give you some earned advice about what to culprits to look for when motors refuse to move.

#### **Motor is jerky.**

Check the tension of the wire rope. The wire rope should be quite taught. Any slack in the rope will cause backlash in the system and make the movement jerky.

Adjust the tuning parameters in Avista (see Avista manual).

#### **Idler pulleys aren’t tracking as the cable moves.**

Lubricate the idler and tension pulley shafts with oil or light grease.

If using diverters (or mule sheaves) move the first set of diverters further from the winch.

#### **When running a cue, the motor speeds fast in the wrong direction and then turns off.**

The polarity of the motor is reversed. Open up the motor plug and switch the white and black wire.

#### **When running a cue, the motor speeds fast in the right direction and then turns off.**

Check to make sure that the encoder is still attached to the motor securely.

Check the encoder connector.

## ***Technical Support***

Though we try our best to produce reliable products and clear instructions, there may come a time when you need personal support.

## **Phone Support**

You can call our technical support at 401-862-2980 Monday-Saturday from 8am – 6pm EST. Phone support is free for 90 days, after that a rate of \$30/hr. applies to support calls.

## **Web Support**

There is an active user support forum on our website.

<http://www.creativeconners.com/phpBB2/index.php>

## **Email**

If you have a technical question you can email technical support

[support@creativeconners.com](mailto:support@creativeconners.com).

## 4 – Specifications

### 4.1 Physical Specifications

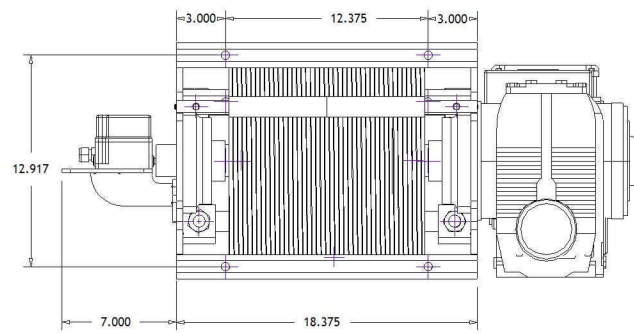
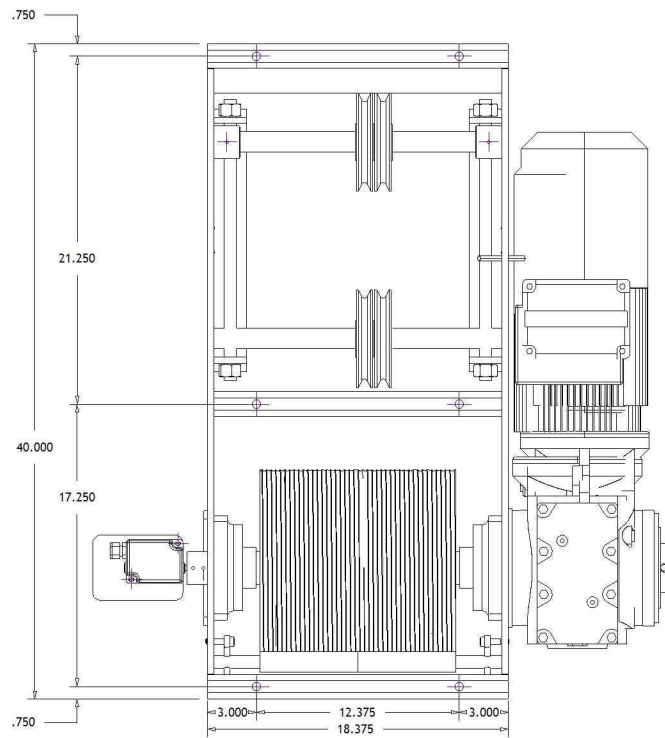

## 4.2 Specifications

Input voltage	
2hp AC, 5hp AC	230V 60Hz 3-phase
2hp DC	180VDC
Max input current	
2hp AC	6.3 amps
2hp DC	10.9 amps
5hp AC	13.6 amps
Max line pull	
2hp	380 lbs.
5hp	1000 lbs.
Max line speed	27"/sec.
Max wire rope size	1/4"
Max wire rope capacity	130'